

USER MANUAL

GASOLINE SCOOTER

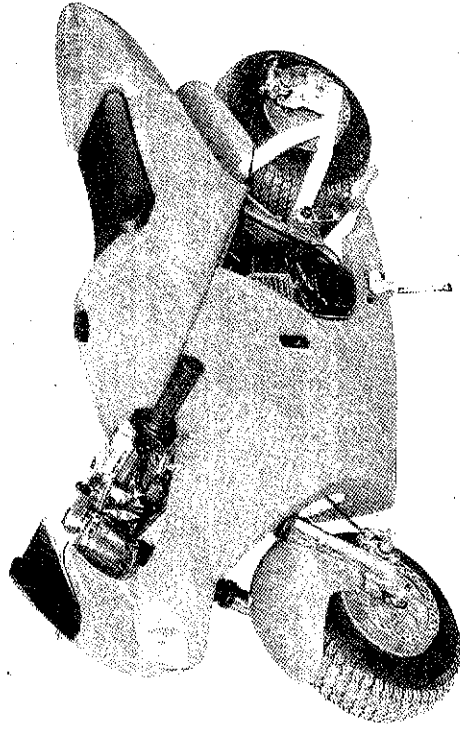

General Information about X-Treme Electric Scooters

Visit: www.x-tremescooters.com/

Technical support

visit www.x-tremescooters.com/technical.html

Order parts for your electric scooter

visit: www.x-tremescooters.com/service.html

Periodic inspection list

Interval Item	Before daily operation	Every 50hours	Every 100hours	Every two hours
Check bolts and nuts, and retighten as necessary.	<input type="checkbox"/>			
Check for fuel leak.	<input type="checkbox"/>			
Check and clean air cleaner.	<input type="checkbox"/>			
Clean the cooling air intake port, cooling fins, muffler and surroundings.	<input type="checkbox"/>			
Check and clean spark plug.		<input type="checkbox"/>		
Check and clean fuel filter.		<input type="checkbox"/>		
Clean muffler and cylinder of carbon.		<input type="checkbox"/>		
Clean spark arrester.		<input type="checkbox"/>		
Replace spark plug.			<input type="checkbox"/>	
Replace the fuel pipe.				<input type="checkbox"/>

Illustration of fixing fuse:

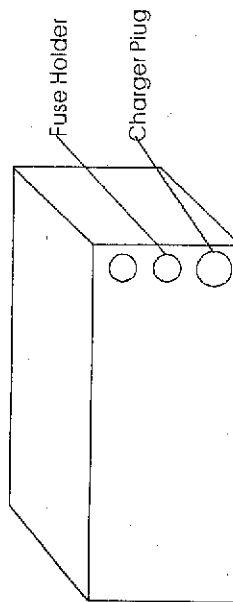

Remove the fuse cover, which on the battery box from the right side of the scooter, then fix the fuse.

Contents

Safe for use (caution!)	1-3
Technical specifications	4-5
Main parts description	6
Preparation before start-up	7
Start-up	8-9
Means of charge	10
Operation and running	10-12
Stopping	12
Maintenance	12-13
Storage	13
Trouble shooting	14-15
Circuit diagram	16
Product composition of picture	17
Composition parts description	18
Periodic inspection list	19

SAFE FOR USE (CAUTION!!)

This mark notifies a very important item for safety. Be sure to observe the notice.

PROHIBITED ITEMS

- * Do not allow anyone who does not understand this instruction manual to operate the gasoline scooter.
- * Gasoline scooters should use mixture of the unleaded gasoline and the two cycle engine oil. The volume ratio is 25-30:1. Do not use any degraded fuel (which smells sour) or fuel of wrong mixture ratio. It will cause a poor start, insufficient output or damage the engine.
- * Do not use 4 cycle engine oil. (Otherwise, it causes the plug to be degraded, the piston ring to seize or the muffler to be clogged.)
- * Do not run the engine in a room or poorly ventilated area. (the exhaust gas includes odorless but hazardous carbon monoxide.)
- * Do not put your hand or foot near any moving or rotating part of engine.
- * Do not store, spill or use any gasoline near a fire, stove, oven, boiler or other instruments which uses a pilot light or spark. (Otherwise, it may cause an explosion.)
- * Smoking is strictly prohibited while refilling the fuel.
- * While the engine is running or while it remains hot soon after stopping, do not remove the lid of the fuel tank or refill the fuel. (Before or refilling the fuel, stop the engine and cool it down 2 minutes or more.)

Composition parts description

- | | |
|-------------------------------|--------------------------|
| 1. frame | 35. controller |
| 2. rear fork | 36. gasoline tank |
| 3. rear shock | 37. muffler |
| 4. outer hexagonal nut | 38. rear fenderboard |
| 5. gasket | 39. motor base |
| 6. bearing cover | 40. inner hexagonal bolt |
| 7. bearing | 41. kickstand |
| 8. front axle | 42. inner hexagonal bolt |
| 9. front brake | 43. footrest |
| 10. cruciate bolt | 44. bearing |
| 11. front wheel | 45. rubber gasket |
| 12. front decelerator | 46. bearing |
| 13. inner hexagonal bolt | 47. double chain wheel |
| 14. front-left shock | 48. spring |
| 15. front-right shock | 49. bearing |
| 16. left braking handle tube | 50. spring gasket |
| 17. left revolving handlebar | 51. outer hexagonal nut |
| 18. left braking handlebar | 52. rear decelerator |
| 19. right braking handlebar | 53. decelerator base |
| 20. right revolving handlebar | 54. rear chain wheel |
| 21. up-fixer | 55. flywheel |
| 22. down-fixer | 56. rear wheel |
| 23. bush | 57. rear brake |
| 24. gasket | 58. rear jack |
| 25. nether connector panel | 59. chain |
| 26. caannuration | 60. engine |
| 27. horn | 61. front fenderboard |
| 28. upper connector panel | 62. cruciate bolt |
| 29. seven piece part | 63. down cover |
| 30. screw | 64. front cover |
| 31. meter | 65. weather board |
| 32. meter base | 66. cover |
| 33. battery box cover | 67. taillight |
| 34. battery | 68. saddle |
| | 69. headlight |

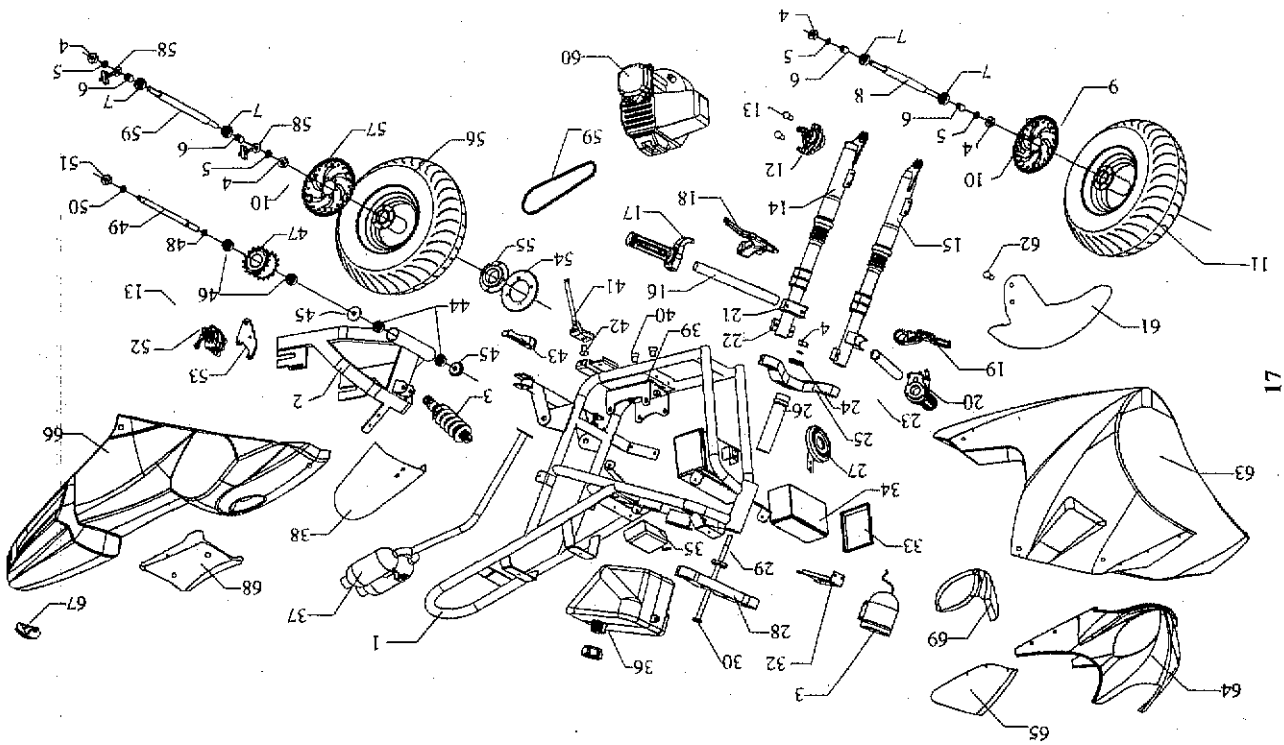

- * If any gasoline spilt or smeared or any danger of explosion is felt, do not run the engine
- * Do not stop the engine while choke lever in the close position.
- * Do not aimlessly adjust the revolution speed setting of the engine
- * Do not check any spark while keeping the spark plug removed
- * Do not run the engine with the muffler or air cleaner cover removed
- * Do not touch any hot muffler or engine part. (Otherwise, it may cause a burn.)
- * When the engine runs, do not touch any spark plug cap or high tension cord. (Otherwise, it may cause an electric shock and harm your body.)
- * Do not force or repeat using electric start at the lack of accumulator voltage. (Otherwise, the starting engine will be damaged.)
- * Do not run any engine as a single unit. (Be sure to run with the gasoline scooter.)
- * ALWAYS WEAR HELMET & SAFETY GEARS.
- * ALWAYS CHECK THE BRAKE INSTRUMENTS BEFORE RIDING.
- * DO NOT RIDE IN RAINING, SNOWING DAY, SLIPERY SURFACE, OR UNSTABLE DUE TO GRAVEL, SAND etc.

*DO NOT RIDE IF YOU ARE UNDER 16 YEARS OLD.

*PREGNANT PERSONS SHOULD NOT USE THIS PRODUCT.

*NEVER USE ALCOHOL OR DRUGS BEFORE OR WHILE OPERATING.

*DO NOT STOP THE SCOOTER SUDDENLY. (Run slowly 3-5 minutes after start-up or before stopping.)

*DO NOT RIDE IF YOU WEIGHT OVER 250lbs

*ALWAYS USE NEW GASOLINE. (If any oil, gasoline is used, some sticky material may stick to inside the carburetor, causing the engine to run poorly.)

*BEFORE STARTING THE ENGINE, MAKE SURE THAT NO PERSON OR FUELFILLED TANK IS PRESENT WITHIN A RADIUS OF 15m.

*This scooter does not confirm to federal motor vehicle safety standards and is not intended for operation on pedestrian, street, highway and freeway.

Please check with your local DepL of Motor Vehicles for regulation in your country.

Circuit diagram

1. Circuit diagram of electrical strat-up

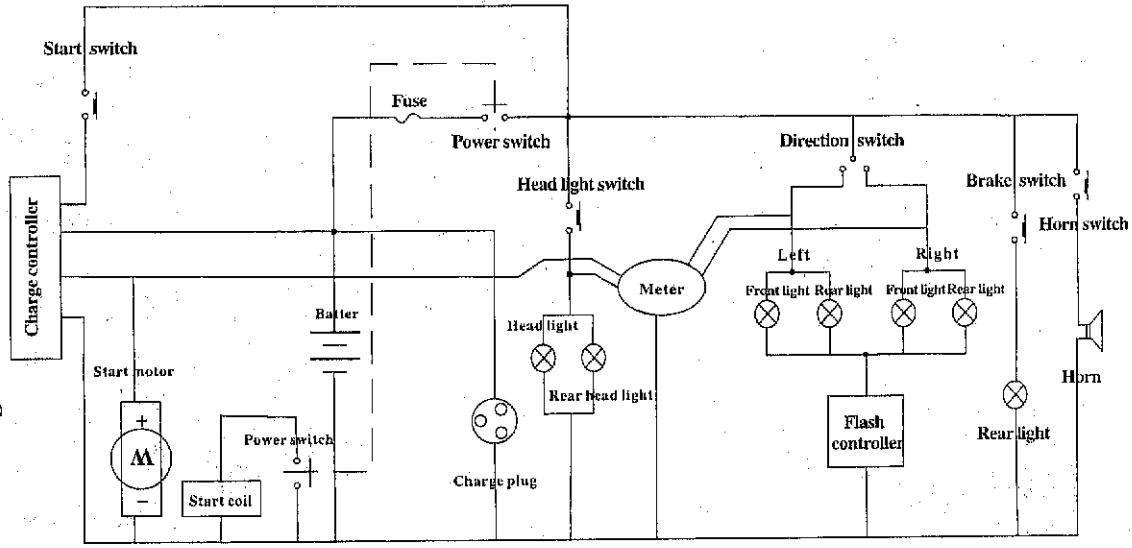

TECHNICAL SPECIFICATION

- (5). May be there is water in the gasoline.
- (6). The air hole of the tank lid is blocked by dust.
- 5. No charging the battery or charging not be well.
 - (1). The charger is spa- lked over.
 - (2). The battery is destroyed.
 - (3). The starting motor is damaged.
- 6. Can't stop engine.
 - (1). The stopping wire of switch is open circuit.
 - (2). The start switch is short circuit; the electro. motor is in the electrifying state all long.

1. ENGINE TYPE: 43CC/49CC SINGLE-CYLINDER/AIR-COOLED/2-STROKE

OEM TO MITSUBISHI CHINA

2. FUEL: UN LEADED PETROL+ 2 CYCLE ENGINE OIL (JASO FC Class)

Volume of Ratio: **25:1**

3. HEADLIGHT, TAILLIGHT, TURNINGLIGHT & HORN

4. FIRE MODE: CDI

5. START-UP: MANUAL (With Recoil Starter Grip)/ELECTRICAL START-UP

6. BRAKE: FRONT & REAR DISK BRAKE

7. TIRE: 13 inch vacuum air tire

8. MAX SPEED: 42km/h(45km/h)

9. MAXIMUM LOAD: 300lbs

10. NET WEIGHT: 90lbs

11. PRODUCT SIZE: 51x13.8x25.6 inch

12. CARTON SIZE: 51.6x14x30 inch

13. SHAFT DISTANCE: 70cm+10

14. MAX CAPACITY/ROTATION SPEED: 1.25/6500(km/r/min) 1.51/6500(km/r/min)

15. FUEL CONSUMPTION < 680(g/kw.h)

16. BATTERY: DC 12V/7AH(9AH)

Trouble shooting

17. FUEL CAPACITY: 1.5L

18. ENGINE PARAMETER:

- (1). IDLING CURRENT $\leq 8A$
- (2). ANTICLOCKWISE CURRENT $\geq 160A$
- (3). ANTICLOCKWISE TORQUE (NM) ≥ 8
- (4). MAXIMUM ROTATION SPEED (r/min): 10000
- (5). CHARGING VOLTAGE (V): 14.8 ± 0.2
- (6). CHARGING CURRENT $\leq 3A$
- (7). ROTATION SPEED OF INITIAL CHARGE (r/min): 5500

1. Fail to start

- (1). Gasoline mixed with water, Please replace it.
 - (2). The spark plug has accumulated carbon or has been broken through.
 - (3). Poor contact of the high-voltage wire with the spark plug.
2. The engine can start, but can't run speedily
- (1). The choke is open totally or not.
 - (2). The ratio of the engine oil and the gasoline is normal or not.
 - (3). Maybe there is water in the gasoline.
3. The gasoline engine can run, but has not enough power.
- (1). Maybe the air filter is blocked by dust.
 - (2). Maybe the cylinder exhaust and the muffler are blocked by the accumulated carbon.
 - (3). The piston, the piston rings and cylinder have been badly worn out.
 - (4). Maybe the fuel strainer is blocked by dust.
 - (5). The body or the top of the shaft has oil leakage and air leakage.
4. The gasoline engine stops suddenly when running.
- (1). Run out of the gasoline.
 - (2). The high-voltage wire drops.
 - (3). The spark plug has accumulated carbon or has been broken through.
 - (4). The fuel strainer is blocked by dust.

Main parts description (see graph 1)

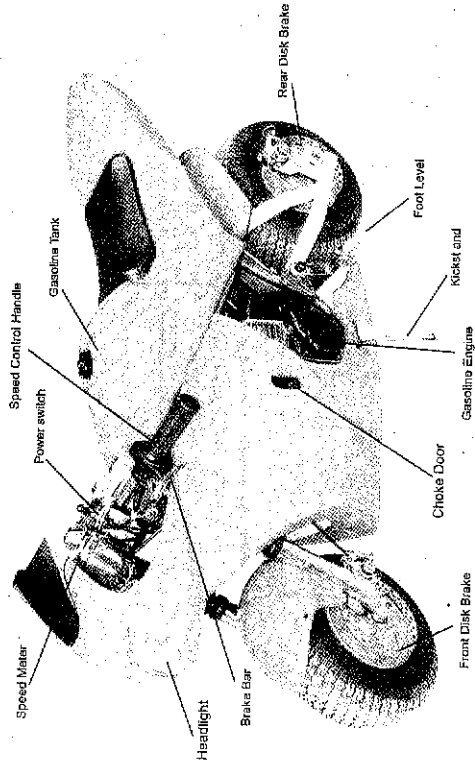

2. Check after running 20 hours
 - (1). Clean the air filter.
 - (2). Clean the fuel strainer.
3. Check after running 50 hours
 - (1). Refasten the nuts of the cylinder.
 - (2). Clean the accumulated carbon both in the combustion chamber and in the exhaust of the cylinder.
 - (3). Clean the accumulated carbon in spark plug; adjust the clearance to 0.5-0.7

mm. (see graph6)



(graph 6)

Storage

If the scooter isn't used for a long time, it must be maintained as follows:

1. Remove the fuel in the tank and in the carburetor, close the choke totally, draw the starter 3-5 times.
2. Take down the spark plug, add certain engine oil from the spark plug hole into the cylinder, and draw the starter 2-3 times to move the piston to the top dead center, then install the spark plug.
3. Use the soft cloth with engine oil to clean the surface of the engine, smear wax on the frame and put the engine to the dry and windy place for the next use.

Preparation before start-up

1. Inspect electric equipment.
2. Refuel
Check key switch, headlight, horn, starting circuit.
2. Refuel
Use the mixture of the gasoline and the two-stroke engine oil. The volume ratio is 25-30:1. (see graph 2) Use a clean and special fuel glass and grasp cap to shake in more than 30 seconds. Don't use mixture oil in more than 1 month.

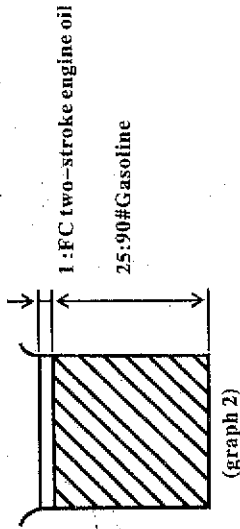

3. Check and clean the air filter
The air filter must be often cleaned, or the polluted air filter will lower the output power of the engine. If the air filter is blocked by dust, use gasoline to clean the air filter, then dip in the oil, wring oil out and put the air filter back.

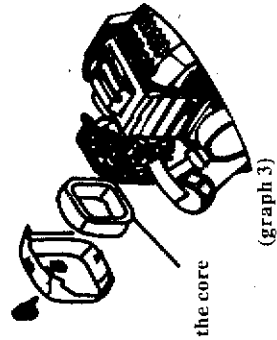

in slant angle. Be careful that scooter is stolen when parking and avoid damaging scooter and other accessories by accident.

7. Transportation

Fold scooter's handle to transport. Push scooter on foot or close engine to run as a non maneuverable scooter. Allow scooter to slip freely.

Note:

- (1). Don't accelerate abruptly due to bad lubrication of the engine at the beginning of start-up.
- (2). Avoid the speedy idle motion and over speed motion. If the throttle is totally opened, the engine will run over speed, which not only shortens the service life of the engine but also causes more problems in the engine.

Stopping

Stop throttle handle or pull down the switch in emergency. But in normal Status, please operate as follows:

1. Reduce the gasoline engine to a lowest speed and run 3-5 minutes.
2. Pull down the stop switch and stop the engine.

Maintenance

1. Daily check
 - (1). Check all screws and nuts and see if they are loosened
 - (2). Check fuel leakage or air leakage.
 - (3). Check whether electric equipment is working.

Start-up

1. Manual start

(1). Turn out the gasoline switch until the gasoline flows out of the clear plastic pipe. (see graph 4)

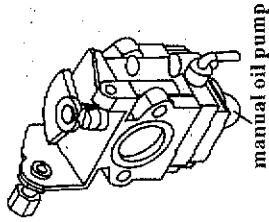

(graph 4)

(2). Close the choke totally (see graph 5). If the engine is heated, the choke must be totally opened

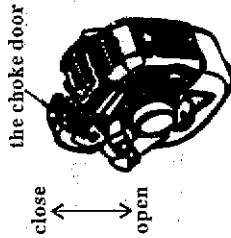

(graph 5)

ar wheel. Please release throttle when brake. Leave enough time to take off. Put down your feet when speed is very slow. Please brake at first if stop totally because of turning or blockage.

4. Turning

Avoid big angle turning which causes inclining seriously to some direction. Circulate more path as soon as possible at a slow speed when turning. Don't turn abruptly or at a high speed, otherwise it in addition, please brake before turning. If brake when turning, it causes losing control due to skidding tires. Release shake handle when turning half.

5. Run in even fields

Stand up or sit down to ride. Don't run on surfaces, which are slick or unstable due to loose gravel, sand etc. Improve alert in these fields. Operate scooter in even field, but don't ride at a high speed. Don't run in uneven, broken or blockage. Inspection distance is determined by speed. But please remember that you avoid it in less time when approach blockage. Watch your running direction. Keep a natural tent between your body and scooter. Pay attention to avoiding uneven pits and broken gravel, sand and other blockage on surfaces. You had better run around blockage or take off to walk around it. Improve alert running. Control scooter at times as a safe, civilized driver.

6. Parking

There is a kickstand in every scooter. Use the kickstand to park your scooter

Means of charge

1. Electric motor

(1). When the motor's speed is higher than 5000r/min, the starting motor will charge the battery until the battery voltage arrives more than rated amount.

(2). At normal using state, the electric current of the starting motor is less than 3A.

(3). The battery will be in short of electric if we don't use it for a long time. When

the battery is in short of electric, we should charge it up by starting motor after handle-start motor or charging up the battery by charger.

Note: Be sure enough charging time when the electric start is often used

2. Manual recoiling engine.

Open key switch, headlight, horn. But engine is not working. Please charge battery by special charger. (Charge plug is on the right of scooter.)

Operation and running

1. After the engine starts, running 3-5 minutes at a low speed.

2. Run as per actual situation when engine is enough heated. Press throttle handle tightly, scooter will run more quickly. Release throttle handle, scooter slides like bicycle. Please release throttle handle and grasp shake handle if you want to stop. Don't throttle before you is not on the scooter.

3. How to use brake handle

Brake instrument is used to brake quickly. Excessive brake causes damaging re-

(3). Open the throttle half.

(4). Draw the starter several times slowly, and then draw quickly.

Note: If the excessive gasoline causes the start difficulty, take down the ignition plug and the input pipe, open the choke and the throttle totally, draw the starter several times, then install the input pipe and start the engine. After the start-up, open the choke totally.

2. Electrical start

(1). Turn on the gasoline switch; Close the choke totally; Open the throttle half.

(2). Pull down the start switch (The start of the motor should work in a short time, pulling down the start switch should less than 5 seconds and forbid to pull down the start switch for a long time).

Note:

1. Forbid to pull down the start switch by the act of "spot start", the "spot start" should finish in a short time. The starting motor can't work.

2. The running sound of the gasoline engines can help you analyze whether the shortage or not at the moment of pulling down the start switch (about 2-5s), if the voltage is enough, the running sound is in order and clear; if not, the running part can't work normally.

3. Pulling down the start switch at first (about 2-5s), you will hear the clear and orderly sound. If the start fails, use the electric start after 5 seconds. If the start fails for 3 times, you should check the motor. Forbid to use electric start often.